

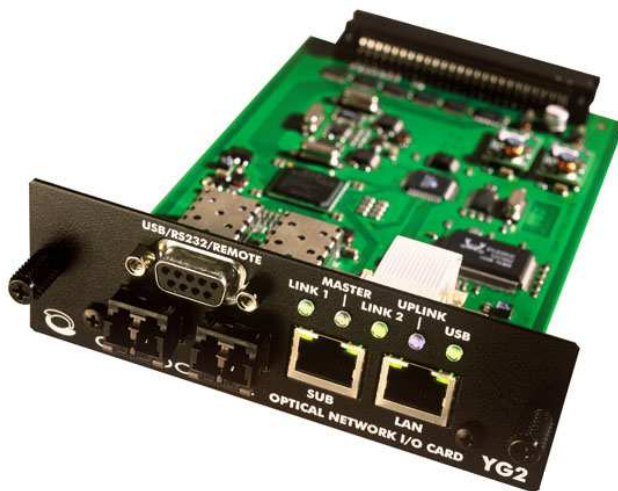

OPTOCORE



Operating Manual for OPTOCORE YG2/YS2

OPTICAL DIGITAL MINI - YGDAI CARDS FOR YAMAHA DEVICES
Optical Network I/O Cards

© Copyright 2007 All rights reserved

OPTOCORE GmbH
Lohenstr. 8
82166 Munich-Gräfelfing
Germany

YG2 / YS2

Operating Manual
Rev. 1.1

Important Safety Instructions

- Please read this manual carefully.
- Please keep this operating manual in a safe place.
- Heed all warnings.
- Follow all instructions.
- Do not use the cards near water, for example, in moist or damp rooms.
- Clean front only with a dry cloth.
- Install the cards in accordance to the operating manual.
- Do not place the cards near any heat source such as radiators, power-amplifiers, stoves, or any other heat producing equipment.
- The cards may only be used in accordance to the information provided in this operating manual. Ensure that all recommendations, especially the safety recommendations as detailed in this operating manual, are followed before and during the usage of the cards.
- Do not place the cards on an unstable table, tripod, cart, etc. The cards may fall, causing serious damage to the cards, and a risk of injury.
- Only use attachments specified by the manufacturer.
- The cards contain no user serviceable parts: only refer to authorized, qualified service personnel for any servicing.
- Your warranty will be voided if you tamper with the internal components.

Purchaser Information

- **Operating Manual**

Please read this manual – if you call for technical support, we'll assume that you have. Study the operating manual carefully in order to familiarize yourself with the cards and its operation. It contains numerous information and hints for the proper use of the cards.

It cannot be excluded that this operation manual shows typographical mistakes or misprints; it is however regularly revised.

Modifications, which serve the purpose of technical improvement of the cards, may be carried out without prior notification.

- **Transport and Shipping**

Always ensure the careful handling of the cards. If not mounted in a console or other Yamaha device, leave and transport the cards in the ESD bag, in which they have been delivered. Use special, shock-absorbing cardboard boxes or transport cases for transport and shipping. The cards may be transported while mounted in a desk.

- **Handling**

To prevent damage through electrostatic discharge (ESD) do not touch the electrical components directly. While inserting the cards into the slot of a console, hold the cards at its front panel or by the use of rack mount screws.

- **Environments**

This device can be used in E1, E2, E3, E4, or E5 environments (as listed below) according to the harmonized European standards EN55103-1 and EN55103-2 "Electromagnetic compatibility – Product family standard for audio, video and audio-visual and entertainment lighting control apparatus for professional use"

E1-Residential

E2-Commercial and light industrial

E3-Urban outdoors

E4-Controlled EMC environment e.g. broadcast and TV-studio

E5-Heavy industry

The product is intended for the use in moderate climate.

- **Water and Moisture etc.**

To prevent fire or shock hazard do not expose cards to the effects of direct sunlight, dust, water, or rain during operation or storage.

- **Cleaning**

Do not clean or touch the electrical components of the cards. Only use a dry linen cloth to clean the front panel of the cards. In case of strong soiling, moisten the cloth using a little water and a small amount of household detergent. Never use cleansing agents containing solvents to clean the cards. Avoid water or moisture to come in contact with electrical components.

- **Operating and Storage Temperature**

Operating temperature: 0°C ...50°C ≙ 34°F ...122°F, ensure proper ventilation

Storage temperature: -20°C ...60°C ≙ -4°F ...140°F

- **Power Supply**

The console in which the card is mounted provides power supply and grounding.

- **Lightning**

For additional protection of the cards during lightning storms, or when they are left unattended and unused for a long period of time, unplug the power line of the console. This will prevent damage to the cards due to lightning and power line surges.

- **Eye Safety**

This product is a Laser Class 1 product. It complies with IEC 60825-1, FDA 21 CFR 1040.10, and 1040.11.

- **Interference of external objects and/or liquids with the cards**

Never push objects of any kind into the cards. They may come in touch with dangerous voltage points or short out parts that could result in a fire or electric shocks. Never spill liquid of any kind on the cards.

- **Cables and Accessories**

Only use attachments specified by the manufacturer.

Only use high quality cable material to connect the cards. For the optical data connection exclusively use the specified optical waveguide cables. If not in use, ensure that the optical connectors of both, card and waveguide are closed with the provided lids.

Do not place the cards on an unstable table, tripod, cart, etc. The cards may fall, causing serious damage to them, and to injury. Any mounting of the cards should follow the manufactures instructions and should use mounting accessory recommended by the manufacturer.

- **Servicing**

Do not attempt to service the cards yourself.

Qualified personnel can change the optical transceivers. Before any attempt to alter the transceivers, please contact your dealer / distributor for instructions. Besides that the cards contain no user serviceable parts: please do only refer to authorized, qualified service personnel for any servicing.

The cards may not be serviced, altered or modified without authorization of Optocore or an Optocore authorized dealer / distributor. Qualified service personnel may only carry out repair and maintenance work. The warranty will be voided if unauthorized manipulation occurred.

CE-Conformity

This document confirms that the product YG2 and YS2 bearing the CE (Communauté Européenne) label meets all requirements in the EMC directive 2004/108/EG laid down by the Member States Council for adjustment of legal requirements. Furthermore the product complies with the rules and regulations of the low-voltage directive 2006/95/EG. This product bearing the CE label complies with the following standards, ratified by CENELEC (Comité Européen de Normalisation Electrotechnique):

Electromagnetic compatibility – Product family standard for audio, video, audio-visual and entertainment lighting control apparatus for professional use

EN 55103-1, Emission

EN 55103-2, Immunity

The authorised declaration and compatibility certification lies with the manufacturer and can be viewed on request. Responsible as manufacturer is:

OPTOCORE GmbH, Lohenstr. 8, 82166 Munich-Gräfelfing, Germany

represented by Marc Brunke, Managing Director

N.B. The awarding of the CE label confirms the compliance with legal directives issued for the manufacture and marketing of electronic and electrical devices. As such the CE label is not a "seal of quality" but rather proof that the device bearing the CE label is conform with the electromagnetic compatibility standards laid down in the above named testing regulations.

Munich, 01.07.2007



Marc Brunke

Eye Safety

This product is a Laser Class 1 product. It complies with IEC 60825-1 and FDA 21 CFR 1040.10 and 1040.11.

YG2 / YS2 Optical Digital Mini - YGDAI Cards for Yamaha Devices

Table of Contents

Important Safety Instructions	2
Purchaser Information.....	3
CE-Conformity.....	5
Eye Safety.....	5
Device Description	7
Front Panel YG2	8
YG2 Cards Details	9
Digital Audio.....	9
LC-Connectors.....	9
HA Remote	9
USB/RS232/REMOTE Auxiliary Port	9
LAN Port	9
SUB Port.....	9
RS232-Connection	9
USB-Connection	9
Protocol.....	9
Transmission Delay	9
Control	10
Front Panel YS2.....	10
YS2 Cards Details.....	10
Digital Audio.....	10
SUB Port.....	10
Starting Up	11
Software Installation	11
Hardware Connection	11
Optocore Network Setup.....	11
Network Example.....	13
Device Compatibility	14
Connection Tables	15
YG2 Cards D-SUB9 Connector	15
YS2 Cards D-SUB9 Connector.....	15
Technical Specifications	16
YG2 Card.....	16
YS2 Card	16
Dimensions and Weight.....	17
Warranty	18
Shipping Contents.....	18
Company Information.....	19

Device Description

Congratulations on your purchase of an YG2 / YS2 Optical Digital Mini - YGDAI Card. The YG2 / YS2 cards will quickly convince you with their advantages and will facilitate your day-to-day work with Yamaha consoles and devices such as the PM or DM series devices. YG2 / YS2 cards offer a broad flexibility in all sorts of temporary and permanent applications, especially when long distance connections, high-quality audio transmission, extremely low latency or high security is required.

The main card YG2 allows a direct connection of Yamaha consoles with the OPTOCORE® OPTICAL DIGITAL NETWORK SYSTEM. The YG2 card is capable to insert up to 64 audio channels IN and extract 64 audio channels OUT of the Optocore network simultaneously. Inserted into the device slot the YG2 exchanges a maximum of 16IN / 16OUT audio channels according to the Yamaha Mini - YGDAI standard with the device.

Additional YS2 sub cards can be inserted into the remaining slots. Connected to an YG2 card via CAT5 cables using the RJ45 "SUB" port, the YS2 cards increase the number of audio channels available at the Yamaha device up to 64IN / 64OUT (32IN / 32OUT @ 96kHz) per YG2 card. Each YS2 card also exchanges a maximum of 16IN / 16OUT audio channels according to the Yamaha Mini - YGDAI standard with the device.

YG2 and YS2 cards can be switched between 8/16-channel mode on the Mini - YGDAI slot via software. Up to 3 YS2 cards can be connected to an YG2 card in 16-channel mode, up to 7 YS2 cards in 8-channel mode. Please refer to Chapter "Device Compatibility" for more information regarding the compatibility of your console or device.

A number of YG2 cards can be inserted into the slots of one device to extend the number of channels handed over to the Optocore network, e.g. a maximum of 128IN and 128OUT by inserting two YG2 cards in an Yamaha PM1D system.

The YG2 front panel offers several outstanding features:

- Two LC-type optical interfaces for data transmission into the Optocore network and connection of any Optocore device for instance the DD32(E), PTP32E, LX4AP.
- One RJ45 LAN port for connection of any standard 10/100MBit Ethernet device, transport of control or any Ethernet compatible data via the Optocore network.
- USB/RS232/Remote (D-Sub-9) port for remote control, software update, connection of external PC, and 2 x RS422 e.g. for transport of Yamaha Remote Protocol to AD8HR by a link to the HA Remote interface of the console.
- Direct pick up of HA Remote signals from the console slot e.g. provided in Yamaha LS9 series.
- One RJ45 SUB port for connection of additional YS2 cards.

The YS2 front panel includes:

- RS232 port for upgrading via PC.
- One RJ45 SUB port for connection of the MAIN port of additional YS2 cards via CAT5 cable.
- One RJ45 MAIN port for connection of the SUB port of additional YS2 or YG2 cards via CAT5 cable

The YG2 / YS2 cards and any other Optocore device on stage e.g. LX4AP linked by a fiber optical cable can easily replace an analog multi-conductor cable, weighting only a fraction of a conventional copper cored one. In 'Yamaha Mode' the YG2 / YS2 cards allow the gain control of Optocore microphone preamps on stage, as provided in LX4AP or X6P-Series, using a Yamaha FOH digital console.

Due to SMD production the YG2 / YS2 cards fulfils the demand of highest digital standards. The FPGA (field programmable gate array) based concept of the internal logic circuitry, permits updating of the hardware via the units remote ports, ensuring continual state-of-the-art cards.

Through the USB or RS232 port of the YG2 card OPTOCORE CONTROL software can control the entire Optocore network. OPTOCORE CONTROL software is used to change the configuration or define own settings. It provides easy access to all configuration and control tools, including routing, naming, gain setting, and phantom power activation for attached devices such as LX4AP and X6, storage and recall of configurations on the computer, off- and online mode, real-time level display of the individual channels in online mode.

Front Panel YG2

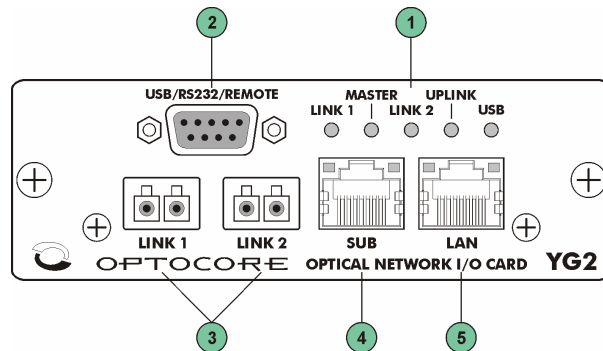

- 1**
- Link 1 LED:** Communication to any other Optocore device is established via LINK 1
Master LED: Indicates that the unit is word clock master of the Optocore network
Link 2 LED: Communication to any other Optocore device is established via LINK 2
Uplink LED: Ethernet communication is established to another Optocore device capable of Ethernet transport
USB LED: Communication to a locally connected PC is established via USB port
- 2**
- USB/RS232/REMOTE:** D-Sub-9 plug containing following interfaces:
 RS232 port for remote control and update via PC
 USB port for remote control via PC
 2 x RS422 ports e.g. for Yamaha HA Remote protocol exchange with console
- Use the TRI-Y cable, provided with the YG2 card. See chapter "Connection Tables" for detailed pin out. For updating via PC a standard RS232 cable is sufficient.
- 3**
- LINK 1:** Full-duplex, full bandwidth LC-type optical interface for data transmission (optical transceiver is changeable)
LINK 2: Full-duplex, full bandwidth LC-type optical interface for data transmission (optical transceiver is changeable)
- 4**
- SUB:** RJ45 port for connection towards the YS2 cards "SUB" port with CAT5 cable
- 5**
- LAN:** RJ45 port for connection of any standard 10M/100M Ethernet device

YG2 Cards Details

Digital Audio

The YG2 digital audio interface is located on the console slot connector. According to the Yamaha Mini - YGDAI standard, the YG2 card features a maximum of 16IN / 16OUT audio channels. Using the OPTOCORE CONTROL software the card can be switched to 8 channel mode for Yamaha devices providing 8IN / 8OUT audio channels, such as the DIO8. (Please refer to chapters "Optocore Network Setup" and "Device Compatibility")

LC-Connectors

The dual, 1Gbps full bandwidth optical interfaces are equipped with LC-connectors, commonly used and absolutely reliable under normal conditions. For rough applications such as touring and rental the 1U OptoCon panel, with rugged and secure fiber optic connectors can be added to a side rack.

HA Remote

The YG2 card supports direct pick up of HA Remote signals from the console slot e.g. provided in Yamaha LS9 series. If the console does not provide the HA Remote signal on the console slot, the signal can be applied externally to the USB/RS232/REMOTE port.

USB/RS232/REMOTE Auxiliary Port

Two RS422 digital channels with a data transfer rate of up to 1Mbps are provided via D-SUB-9 connector on the front panel. The two channels are software patchable to any Optocore device featuring RS485/RS422 auxiliary ports. The Yamaha HA Remote protocol can be applied from the consoles external HA Remote port and transported to any device in the Optocore network by using the provided TRI-Y cable, enabling the connection and remote control of Optocore or Yamaha converters directly from the console.

LAN Port

A 10/100 Mbps Fast Ethernet interface is provided via RJ45 port. All LAN ports of the Optocore devices within the Optocore network form a virtual switch with physically distributed ports. We recommend using a standard CAT5 network cables to connect any Ethernet device such as a standard Ethernet switch for local distribution.

SUB Port

The SUB port offers the possibility to extend the number of channels transmitted to the console if connected to the MAIN port of an YS2 card using a standard CAT5 cable.

RS232-Connection

A RS232 port is provided within the D-SUB-9 connector on the front panel. It can be used to upgrade the cards internal logic or to connect it with the OPTOCORE CONTROL software. We recommend using a shielded, standard 1:1 cable for the RS232 port.

USB-Connection

The D-SUB9 connector also provides an USB port. We recommend using the TRI-Y cable, which is provided with every YG2 card. It allows you to connect with the OPTOCORE CONTROL software.

Please note: **Upgrading the cards internal logic is only possible using the RS232 connection.**

Protocol

The OPTOCORE ® OPTICAL DIGITAL NETWORK SYSTEM uses a digital Time Division Multiplex technology (TDM) with a fiber channel based 8B10B-NRZI-coding. Static time slots guarantee the synchronous transmission of all channels at any time with no demand for dynamic bandwidth.

Transmission Delay

The Optocore system delay, including the matrix, is fixed to 41,6 µs for all channels. The transport delay per Optocore unit (<200 ns) in the network is insignificant. The transmission delay is constant from any point to any point. Overall delay depends on converters and fiber cable length, with 'normal' cable lengths of <700 m it can also be considered as marginal.

Control

Controlling of all devices in the Optocore network including Optocore converter modules is achieved from any unit using the OPTOCORE CONTROL software via RS232 or USB port. Both ports are available using D-SUB-9 connector on the front panel. If previously adapted by Optocore, third party protocols for card controlling can be activated via OPTOCORE CONTROL menu *SET / SPECIAL MODE*, for example the "Yamaha mode" to control the Optocore mice-preamps from a Yamaha-console.

Front Panel YS2

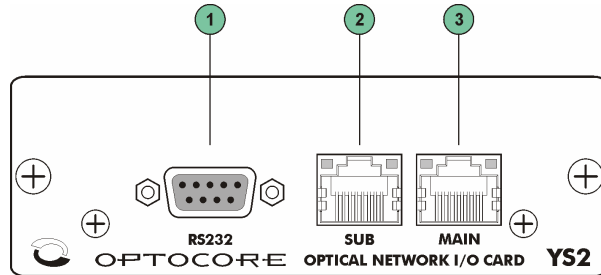

- 1 **RS232 plug:** RS232 port for upgrading the cards internal logic via PC
- 2 **SUB port:** RJ45 port for connection towards the MAIN port of YS2 card with CAT5 cable
- 3 **MAIN port:** RJ45 port for connection towards the SUB port of a YG2 or YS2 card with CAT5 cable

YS2 Cards Details

Digital Audio

The YS2 digital audio interface is located on the console slot connector. According to the Yamaha Mini - YGDAI standard the YS2 card features a maximum of 16IN / 16OUT audio channels. Using the OPTOCORE CONTROL software the card can be switch to 8 channel mode for Yamaha consoles providing 8IN / 8OUT audio channels, such as the DIO8. (Please refer to chapters "Optocore Network Setup" and "Device Compatibility")

SUB Port

The SUB port offers the possibility to extend the number of channels transmitted to the console if connected to the MAIN port of an YS2 card using a standard CAT5 cable.

MAIN Port

The MAIN port is connected to the SUB port of an YG2 card. In a chain of several YS2 cards it is connected to the SUB port of the next YS2 card towards direction of the YG2 card.

Starting Up

In order to install the YG2 / YS2 Mini - YGDAI cards, proceed as follows:

Make sure that the power is turned off. Loosen the screws that hold the slot cover and remove the slot cover. Keep the slot cover in a safe place. Match the edges of the card with the guardrails inside the slot and insert the card. Push the card all the way into the slot ensuring that the connector at the end of the card is correctly mated with the connector inside the slot. Use the screws included with the card to fasten the card in place. Malfunctions or incorrect operation may occur if the card is not fixed correctly.

Software Installation

Installation requirement for the software is a functioning computer system with Microsoft® Windows 95/98/2000/NT/XP/Vista® operating system. The computer should be equipped with an USB interface for configuration and remote controlling, and a RS232 interface (or an appropriate USB / RS232 adapter) for firmware upgrade. COM 1...4 can be used with a transfer rate of 57 600 Baud. Monitor resolutions of 800 x 600 or 1024 x 768 with 16 Bit color rendering are recommended to view the program. The installation requires approx. 2.5MB of hard-disk space and is carried out in the usual Windows-program manner.

Please note that the serial interfaces on computers are not usually capable of “Hot Plugging”. Switch off the computer to avoid damage before establishing the serial connection between the Optocore device and the computer.

The set-up software *OCSETUPXXX.EXE* is available on CD or can be downloaded from www.optocore.com. OPTOCORE CONTROL for configuration and remote controlling, and OPTOCORE UPGRADE for firmware upgrading are installed on a PC or Laptop by double-clicking on the *OCSETUPXXX.EXE*. The set-up executable program is self-extracting and provides the OPTOCORE CONTROL SETUP WIZARD. It will establish the necessary directories, a desktop icon for the OPTOCORE CONTROL and firmware upgrade software.

The uninstall procedure of OPTOCORE CONTROL can be carried out with the *ADD OR REMOVE PROGRAMS* tool of Windows, which is usually found under *START / CONTROL PANEL*.

For details about features and handling of OPTOCORE CONTROL please refer to the *HELP* menu of the software. We strongly recommend getting familiar with the OPTOCORE CONTROL software.

Hardware Connection

To get the YG2 / YS2 card system going, please be sure that the main power of the console is turned off before inserting the cards into the Mini - YGDAI slots. Please refer to your consoles manual for detailed information. Interconnect all cards with the provided CAT5 cables using the SUB / MAIN interfaces as shown in the chapter "Optocore Network Setup". Connect the provided TRI-Y cable for the Optocore network setup via USB port. Do not connect the optical cables yet.

Optocore Network Setup

Before connecting the YG2 card to further Optocore devices by the optical LINK, assure that all devices have a basic set-up in order to be able to operate correctly. For operation safety reasons, some settings (e.g. "ID") are only allowed to be made when locally connected to a device. The best approach to check the settings is to connect locally to every single device of the Optocore network with a PC using either RS232 or USB connection (use the provided TRI-Y Cable for USB), run the OPTOCORE CONTROL software and enter menu *SET / LOCAL SETTINGS*.

The following descriptions only relate to YG2 / YS2 cards settings:

YG2 Card

- **General -> ID:** Set each device in the optical network to a unique ID. Device IDs must be unique in the entire Optocore network. Set the YG2 card inserted in the main console (when using several consoles) to ID1 and check the "Master Priority" flag. This determines the card to be the internal word clock master for the Optocore network.
- **General -> Card ID:** Set the ID to either "MY-16AT emulation" or "MY-8AT emulation" depending on the standards of the console. Please refer to the chapter "Device Compatibility" which settings apply for your console.
- **HA Remote via slot:** Choose the device ID and port of the destination device to which the HA Remote signal should be transmitted. You can only choose the transmit port, the receive port is assigned automatically. Due to the RS422 standard the two ports are unidirectional. For a bi-directional communication between the devices one transmit and one receive path has to be determined. Make sure that both ports of the destination device match the setting of the YG2 card!
- **HA Remote via front-panel-RS422:** If your console does not provide the HA-remote signal on the console slot, choose the destination device ID and its port, to which the HA-Remote Signal should be transmitted and apply the HA-remote signal externally using the provided TRI-Y cable. You can only choose the transmit port, the receive port is assigned automatically. Due to the RS422 standard the two ports are unidirectional. For a bi-directional communication between the devices one transmit and one receive path has to be determined. Make sure that both ports of the destination device match the setting of the YG2 card!
- **Ethernet setup:** In order to use the Optocore network for Ethernet transport, the option has to be activated at every device in the Optocore Network. Currently the Optocore network is capable to transport three CVBS Video channels or one CVBS Video channel plus 100 Mbps Fast Ethernet when Ethernet transport is activated. For the YG2 card the activation is done by marking the two boxes "Optocore Ethernet transport" and "Enable local Ethernet".
- **SUB Setup -> SUB Cards:** Set the number of YS2 cards, you have connected to your YG2 card.

Push button "Write" first, confirm with "OK" and press "Close" to exit the dialog.

YS2 Card

- **General -> Card ID:** Set it either to "MY-16AT emulation" or "MY-8AT emulation" depending on the standards of the console. Please refer to chapter "Device Compatibility" which settings to use for your console.

Push button "Write" first, confirm with "OK" and press "Close" to exit the dialog.

Check your console if all cards inserted in the slots have been recognized correctly (please refer to your consoles manual how to do). If you have changed the default settings for "Card ID", a restart of your console is necessary after the change in order to recognize the cards correctly.

You may now connect the optical LINK cables between all Optocore devices.

Note: When connecting the optical LINK cables, for convenience temporarily remove the TRI-Y cable. This especially counts for removing the optical cables.

Check your set-up by connecting to any device using either RS232 or USB connection, running the OPTOCORE CONTROL software and starting "Online Mode" in the "Set" menu. The entire network at its current state is now displayed in the control software. Check the "log window" for any error messages.

Optionally you may connect the TRI-Y cable to the HA Remote port of your console and attach any Ethernet device to the LAN port of your YG2 card.

Network Example

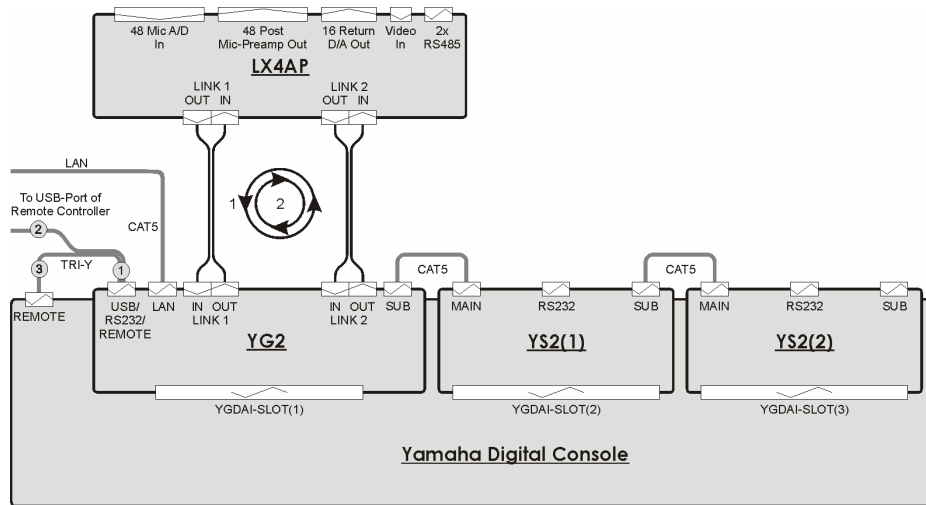

Fig. 1: Example for an Optocore network with LX4AP on stage. Direct Control of LX4AP head amplifiers from the console is achieved by switching the YG2 card into Yamaha Emulation Mode (YEM) using OPTOCORE CONTROL.

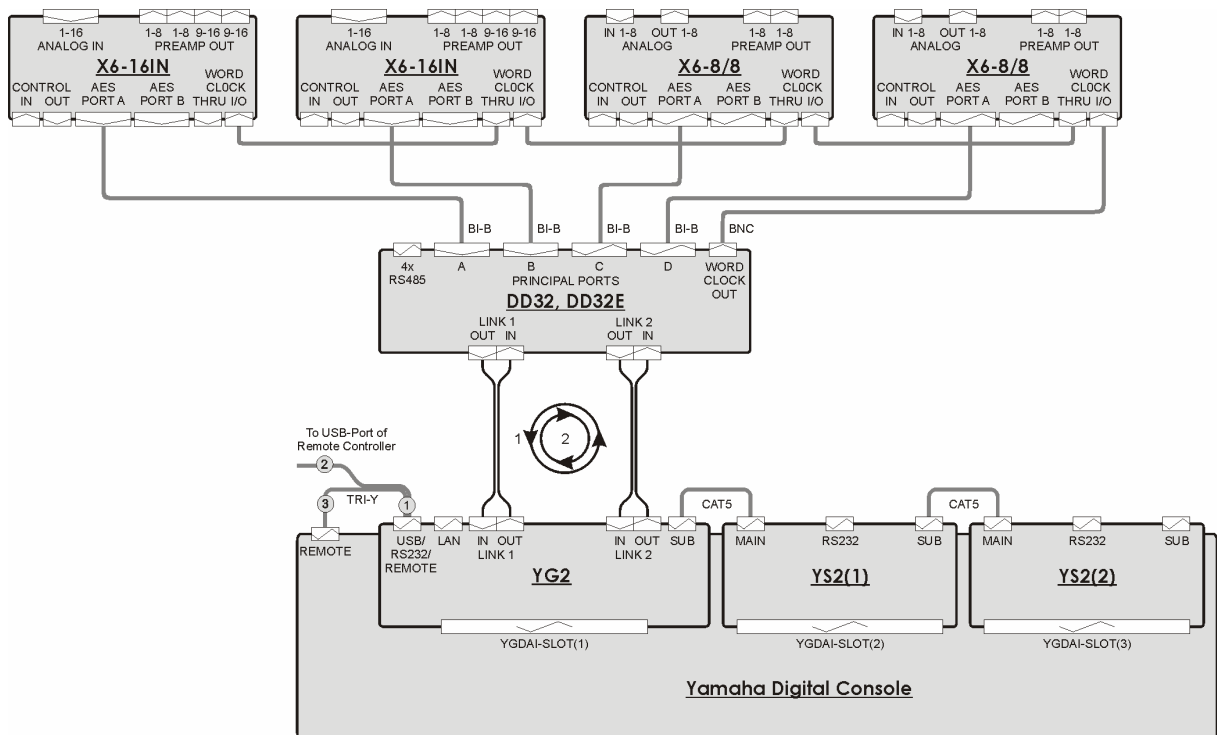

Fig. 2: Wiring of a system with DD32(E), X6-converter units and a Yamaha console with YG2/YS2 cards. In order to control the X6-converter at the console the Yamaha Emulation Mode (YEM) must be activated in OPTOCORE CONTROL. Yamaha preamps connected to the DD32(E) will use the fiber optical connection only for the bi-directional transfer of RS485 data and no special mode is activated.

Device Compatibility

The table below lists Yamaha consoles and devices by the number of IN / OUT audio channels supported on one console slot. Set the YG2 / YS2 cards either to "MY-16AT emulation" or "MY-8AT emulation" according to the number of channels supported.

16 IN / 16 OUT MY-16AT 1 YG2 plus 3 YS2 = 64 IN / 64 OUT	8 IN / 8 OUT MY-8AT 1 YG2 plus 7 YS2 = 64 IN / 64 OUT
PM5D / PM5D-RH	DIO8 for PM1D / PM1DV2
M7CL Series	DME32
LS9 Series (with HA remote transport via slot)	AD824
DM2000	DA824
DM1000	
02R96	
01V96	
DME64N / DME24N	
All future products with Mini - YGDAI slots	

Connection Tables

YG2 Cards D-SUB9 Connector

Pin-out		YG2 RS232/USB/RS422							
	Channel	RS232		USB		RS422		GND	Use 1-modem cable, male – female, to connect to PC. <u>Consider non-standard pinning!</u>
		RXD	TXD	+	-	Port1	Port2		
	Pin	3	2	1	6	4, 9	7, 8	5	
D-Sub-9- female								Locking system acc. to 4-40 UNC	

YS2 Cards D-SUB9 Connector

Pin-out		YS2 RS232							
	Channel	RS232						GND	Use 1-modem cable, male – female, to connect to PC. <u>Consider non-standard pinning!</u>
		RXD	TXD						
	Pin	3	2					5	
D-Sub-9- female								Locking system acc. to 4-40 UNC	

TRI-Y Adapter

The TRI-Y cable combines the two RS422 and the USB-Port for PC connection in one D-Sub-9 connector. It is used to establish the connection from the YG2-Card to a PC USB interface and remote interface of a console.

YG2 Auxiliary Port 2 x RS422 and USB port
 D-Sub-9-male
 Fastening system 4-40 UNC
 X1...X2: RS422
 X2...X3: USB

PC USB
 Type A
 X3: T/R x D

COM RS422
 D-Sub-9-female
 Fastening system 4-40 UNC
 X1: R x D
 X2: T x D

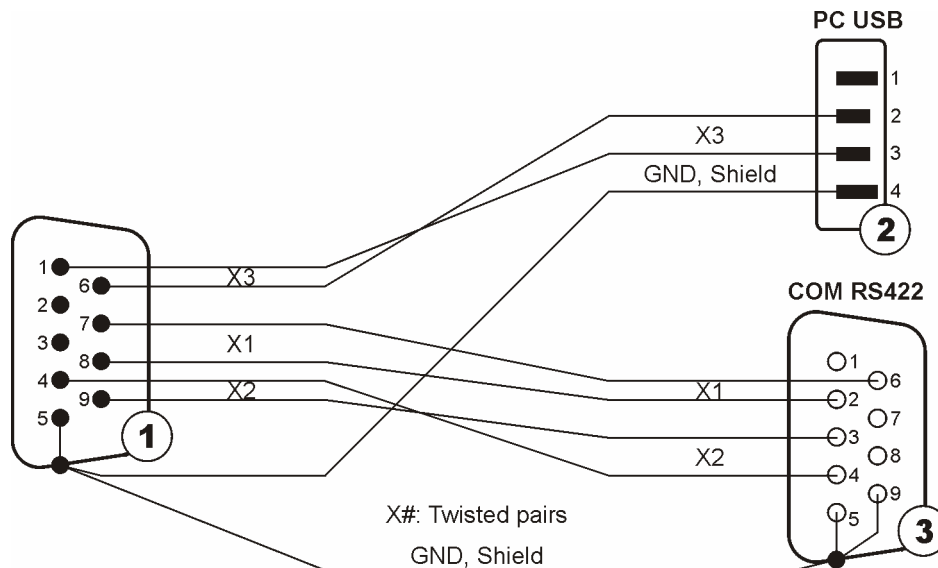

Technical Specifications

YG2 Card

Digital Audio (Mini - YGDAI Slot)	Convention Mini - YGDAI Interface	
HA-Remote (Mini - YGDAI Slot)	Convention Mini - YGDAI Interface	
Data channels	Digital control data	TX / RX up to 1Mbps
Word Clock (Mini - YGDAI Slot)		
Data rate	Dependant on used sample rate	44.1 / 48 / 88.2 / 96kHz +/-100ppm
Optical LINK	Input, Output, Dual – Full bandwidth	
Connection	Duplex LC 50 / 125	
Digital Optical Network System	Optocore	
Transmission art	Full duplex	
Data rate	2 x 1Gbps	
Length of optical waveguide cable	Multimode fiber 50µm	≤ 700m
	Multimode fiber 62.5µm	≤ 350m (not recommended)
	Monomode fiber 9µm	up to 70km (on request)
Auxiliary Ports	Convention EIA / TIA - 422	
Data channels	Digital control data	1 IN / 1 OUT up to 1Mbps
RS232 Port	Convention EIA / TIA - 232	
Data channels	Digital control data	R x D, T x D
Data rate	57 600 Baud	
SUB Port	Convention Optocore 64 channel CAT5	
Cable Type	ANSI/TIA/EIA-568-A, TSB-95	CAT5
Max. Cable length	10 m / 33 feet	
USB Port	Remote control connection	USB 1.1 full speed

YS2 Card

Digital Audio (Mini - YGDAI Slot)	Convention Mini - YGDAI Interface	
SUB / MAIN Port	Convention Optocore 64 channel CAT5	
Cable Type	ANSI/TIA/EIA-568-A, TSB-95	CAT5
Max. Cable length	10 m / 33 feet	
RS232 Port	Convention EIA / TIA - 232	
Data channels	Digital control data	R x D, T x D
Data rate	57 600 Baud	

Dimensions and Weight

Cards Dimensions

YG2 / YS2 Card

H x B x T:	100 x 160 x 40	[mm]
H x W x D:	3.94 x 6.3 x 1.57	[inch]

Cards Weight

YG2 Card

Weight: 365 g / 12.88 ounces

YS2 Card

Weight: 175 g / 6.17 ounces

Package Dimensions

YG2 / YS2 Card

H x B x T:	170 x 225 x 85	[mm]
H x W x D:	6.69 x 8.86 x 3.35	[inch]

Package Weight

YG2 Card

Weight: 540 g / 19.4 ounces

YS2 Card

Weight: 320 g / 11.3 ounces

Modifications, which serve the purpose of technical improvement of the cards, may be carried out without prior notification.

Warranty

Summary of Warranty

Optocore YG2 / YS2 cards is warranted against defects in material and workmanship for 24 months.

This warranty covers the original purchaser only and is not transferable. Valid evidence for warranty is the official Optocore invoice issued by the distributor.

Optocore will, at its discretion, repair or replace a defective product, providing that the defect has appeared under normal operating conditions.

This warranty does not cover damage from acts of God, accident, abuse, neglect, contamination, unauthorized modification or misuse, operation outside of the environmental specifications for the product, improper site preparation or maintenance, or abnormal conditions of handling. This would include over-voltage failures, and conditions outside of the products specified ratings, problems with buyer-supplied software or interfacing, or normal wear and tear of mechanical components. Optocore or its distributor will acknowledge the evaluation of warranty after inspection.

Cards on which the Serial Number has been removed or defaced are not eligible for warranty service.

Failure to properly package and protection of the product during shipping may void this warranty.

How to Obtain Warranty Service

To return a defective product, please contact your dealer / distributor. Our web site: www.optocore.com provides a complete list of Optocore dealers / distributors.

Always ensure the careful handling of the cards. If possible transport or shipping should always occur in special, shock-absorbing transport cases. If these are not available we recommend well-upholstered packaging. We strongly advise not to use simple flight-cases without rack-in-rack mounting.

Declaration of Liability

Optocore accepts no liability for damage caused to other devices through operation of the YG2 / YS2 cards.

Optocore is not liable for any damage caused by shipping accidents, misuse, abuse, operation with incorrect voltage, operation with faulty peripheral equipment, or improper or careless installation of the cards.

Optocore accepts no claims for compensation whatsoever (e.g. cancellation of events).

Shipping Contents

YG2 Card

The standard shipment of an YG2 cards contains the following:

- 1 x YG2 Yamaha Mini - YGDAl card
- 1 x TRI-Y Cable
- 1 x Optical patch cable, length 2 m / 6.5ft, LC to SC type connectors, fiber 50µm (multi-mode)
- 1 x operating manual

YS2 Card

The standard shipment of an YS2 cards contains the following:

- 1 x YS2 Yamaha Mini - YGDAl card
- 1 x CAT5 Cable, length 0,25 m /0.82 ft

Any additionally purchased equipment such as optical waveguide cables in required lengths, D-Sub cables and adapters, RS232-cables, and international electric cables have been supplied on your request and your purchase order and cannot be listed in the above.

Company Information

Mailing Address:

OPTOCORE GmbH
Lohenstr. 8
D-82166 Munich-Gräfelfing
Germany

Telephone:

+49 – (0)89 – 8999640

Facsimile:

+49 – (0)89 – 89996455

Internet:

www.optocore.com

E-mail:

Inquiry@optocore.com